

# ***RENOLD***

## **SECTION 2**

### **CHAIN INSTALLATION & MAINTENANCE**



# WARNING

## HEALTH AND SAFETY WARNING

*The following precautions must be taken before disconnecting and removing a chain from a system prior to replacement.*

1. Always isolate the power source from the drive or equipment.
2. Always wear safety glasses.
3. Always wear appropriate protective clothing, hats, gloves and safety shoes as warranted by the circumstances.
4. Always ensure tools are in good working condition and used in the proper manner.
5. Always loosen tensioning devices.
6. Always support the chain to avoid sudden unexpected movement of chain or components.
7. Never attempt to disconnect or reconnect a chain unless the chain construction is fully understood.
8. Always ensure that directions for the correct use of any tools are followed.
9. Never reuse individual components.
10. Never reuse a damaged chain or chain part.

**N.B. Breach of these practices could result in serious injury or death.**

## Chain Installation and Maintenance

### Introduction

Renold Chain has over 100 years' experience in the operation and maintenance of transmission chain. Involvement with designers, manufacturers and users of all types of equipment has enabled Renold to develop this definitive guide, designed to pass on the preferred methods of correct handling, adjustment, installation and maintenance of transmission chain drives resulting in maximum chain life.

Should you require any further information, please contact our technical sales staff.

2

### Equipment Needed

The breaking of chain can be achieved by using a Renold Chain Extractor, these being:-

- 311015 for light industrial chains up to 0.5" pitch.
- 10101 for chains from 0.375" to 0.625" pitch
- 10102 for chains from 0.75" to 1.25" pitch

For joining any chain up to 2.5" pitch, a drift punch will be required.

Erection of medium or heavy chain drives requires millwrighting equipment such as lifting tackle, slings, wedges, packing, etc.

### OTHER USEFUL EQUIPMENT

- Quantity of inner and outer links.
- Straight edges and/or strong, fine line.
- Spirit level.
- Plumb line.
- Selection of hammers, files, key blanks, etc.

### Preparation

Check equipment to ensure that general transmission requirements are correct (e.g. flexible couplings, flywheel, means of drive adjustment).

Check condition and rigidity of the shafts and bearings, particularly if there has been considerable previous service with an alternative method of transmission. Replace or rectify if necessary.

Driver and driven shafts should be checked to ensure they are level and parallel to each other. This applies equally to the jockey shaft if present.

Use a spirit level and adjustable comparator bar or micrometer between shafts at extreme points on each side of the drive. Rectify any parallelism error present and mark a permanent datum line for the adjustable shaft.

Place sprockets or respective shafts in approximate alignment and fit the keys in accordance with correct engineering practice. Do not finally secure keys at this stage.

Care must be taken with sprockets of split design to ensure perfect abutting of the faces of each half. Proceed with the key fitting after the halves are finally bolted together, otherwise the key can prevent correct assembly and subsequently result in malgearing.

It should be verified that key heads will not project beyond the width of any chaincases.

### Checking Sprocket Alignment

Accurate alignment of shafts and sprocket tooth faces provides a uniform distribution of load across the entire chain width and contributes substantially to maximum drive life.



Use a straight edge across the machined faces of the sprockets in several different positions, if possible, as a check against wobble. A nylon or similar line is a good substitute for a straight edge particularly on longer centre distances.

Should endwise "float" of shafts be present, make due allowance so that sprocket alignment is correct at the mid position of "float".

When alignment is correct within closest practical limits, drive the keys home and take a final check on sprocket alignment.

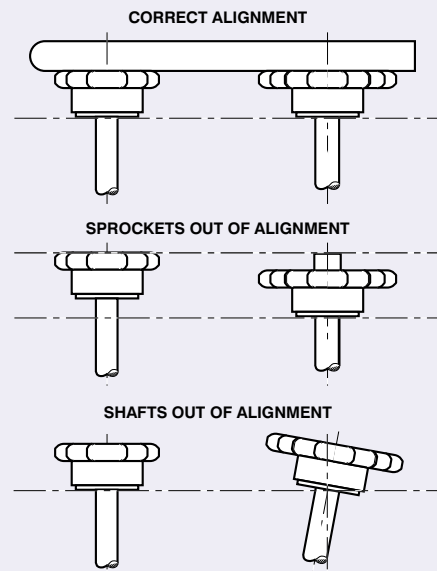

### IMPORTANT NOTE

Sprockets should always be designed to be as close to the supporting bearings as possible.

### Installation of Chain

Renold Chain should not be assembled on the sprockets until attention has been paid to:

1. Cleanliness of the sprocket teeth, particularly if debris of an abrasive nature (cement dust, weld spatter, etc.), has been prevalent whilst work was in progress.
2. Temporary positioning of the lower section of a chaincase if present. In restricted spaces, manoeuvring of large sections is often simplified by using the spaces between shafts which will later be occupied by the chain.

Ensure the chain is clean and free from debris and place around the sprockets, observing instructions where matched strands are involved. In chain of two or more strands, joining is most easily accomplished at the mid span of the drive, drawing the chain ends together with a chain clamp or rope tackle block. Ensure that the strength of the drawing tackle is sufficient to hold the chain. Chain weights are shown in the Renold catalogue. When inserting the joining link of multiplex chain, ensure the intermediate plates are assembled. Do not detach the drawing tackle until the link is completely assembled. When only partially inserted through inner links, the weight of the chain on release can "splay" unsupported bearing pins.

Adjust the chain using the datum mark mentioned in the preparation section to retain shaft parallelism.

For a chain of average centre distance (30-50 x chain pitch) correct adjustment is when the mid point of the longest span can be fully moved by hand in accordance with dimension 'A' shown in diagram one.

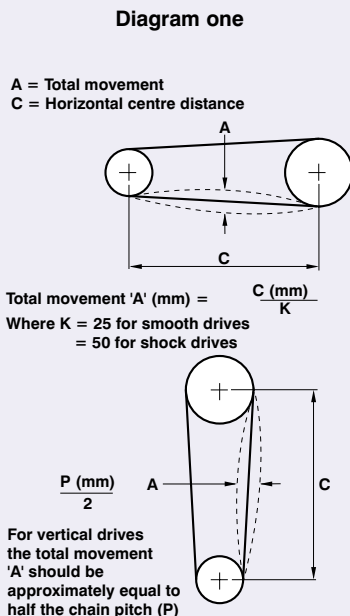

Over-tensioning should be avoided in all cases.

### CHAINCASES

- Position the chaincase bottom sections with the shafts concentric in their cavities.
- Manufacture suitable mountings and brackets to ensure rigidity.
- Assemble the oil supply and return pipe system and the drive to the oil pump.
- Assemble top section(s) of chaincase.
- Fill the oil sump and check delivery to the chain.

### Chain Adjustment

To maximise chain life, some form of chain length adjustment must be provided, preferably by moving one of the shafts. See diagram three. If shaft movement is not possible, an adjustable jockey sprocket engaging with the unloaded strand of the chain is recommended. Generally, the jockey should have the same number of teeth as the driver sprocket and care should be taken to ensure speed does not exceed the maximum ratings shown.

The chain should be adjusted regularly so that with one strand tight the slack strand can be moved a distance of 'A' at the mid point. See diagram one, on this page.

To cater for any eccentricities of mounting, the adjustment of the chain should be tried through a complete revolution of the large sprocket.

Adjustment, as shown in these diagrams, is achieved either by the movement of one of the shafts or by use of the jockey sprocket. The amount of the adjustment provided by either method should be sufficient to take up chain wear amounting to two pitches or two percent elongation above nominal chain length, whichever is the smaller.

**Diagram two**

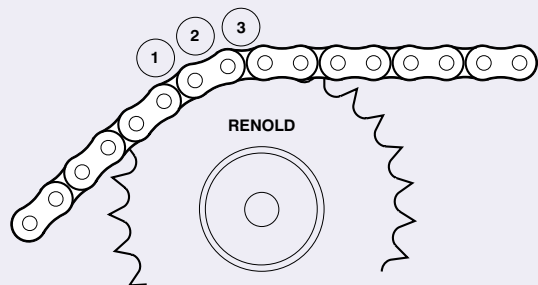

When used for adjustment, a jockey should be positioned on the unloaded side of the chain, preferably nearer to the driven sprocket and gearing with the outside of the chain; it should have an initial chain lap of at least three teeth and a free length of chain not less than four pitches between it and the nearest sprocket. See diagram two above.

Generally, the number of teeth in any jockey should not be less than the smallest sprocket and care should be taken to ensure that the speed does not exceed the maximum recommended. Where necessary, several sprockets can be used on a single drive, thereby meeting all possible needs for adjustment.

## Chain Installation and Maintenance

2

All mountings for jockeys should be rigid and when manual adjustment is provided, the moving member must be securely locked in position after adjustments have been made.

Diagram three

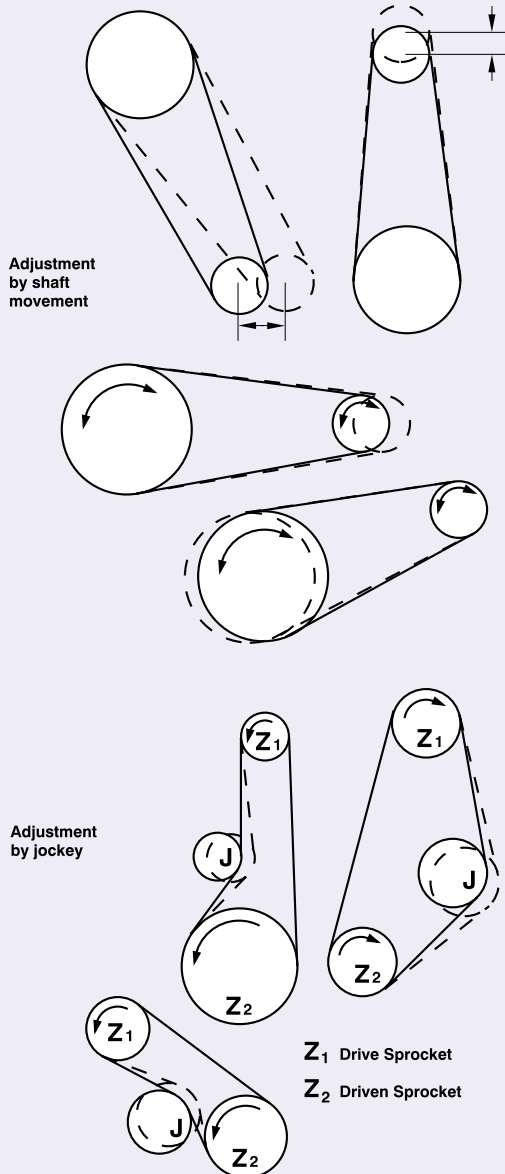

### AUTOMATIC ADJUSTMENT

Automatic adjustment can also be provided, but this adjustment generally demands a special study of the conditions to enable a suitable design to be provided.

### Test Run

It is advisable to give the drive a short test run for the following reasons:

1. To regulate oil delivery to the chain.
2. To eliminate any oil weeps from the chain case and pipework.
3. To check for any unusual noise or vibration.

### Maintenance Schedule

Regular chain maintenance is important if maximum life is to be achieved. In a correctly sized and installed drive the chain can be expected to last for approximately 15,000 hours.

The following maintenance schedule is suggested.

#### AFTER 3 MONTHS

- Check chain adjustment and rectify if necessary.
- Change oil, oil filter and clear the sump.

#### ANNUALLY

- Carry out the above checks.
- Check for wear on side plates.
- Check for chain elongation.
- Check cleanliness of components.
  - Remove any accumulation of dirt or foreign materials.
- Check for shaft and sprocket alignment.
- Check for wear on sprockets.
- Check the condition of the lubricant.
- Check the lubrication system.
  - Feed pipes are not clogged.
  - Lubrication schedule is being followed (manual lubrication).
  - Drip rate is sufficient (drip system).
  - Oil level is correct (drip, bath and disc systems).
  - Pump is working (stream system).

### Chain Protection

A new Renold chain should always be stored in its box and/or bag until installation. Renold chain is lubricated at the factory, but this lubrication will not stand up to outdoor conditions, particularly where there is a salt water atmosphere.

Unprotected, lubricated chains will become contaminated with grit and other materials which will harm the chain and tend to clog strainers, filters and oil lines. A roller chain is a precision made series of bearings that will perform best if handled and stored in correct conditions.

### Lubrication

Renold Chain drives should be protected against dirt and moisture and be lubricated with good quality, non-detergent petroleum based oil. A periodic change of oil is desirable as already outlined. Heavy oils and greases are generally too stiff to enter the chain working surfaces and should not be used.

Care must be taken to ensure that the lubricant reaches the bearing area of the chain. This can be done by directing the oil into the clearances between the inner and outer link plates, preferably at the point where the chain enters the sprocket on the bottom strand.

The table below indicates the correct lubricant viscosity for various ambient temperatures.

Ambient Temperature Celsius	Lubricant SAE	Rating BS4231
-5 to +5	20	46 to 68
5 to 40	30	100
40 to 50	40	150 to 220
50 to 60	50	320

For the majority of applications in the above temperature range, a multigrade SAE 20/50 oil would be suitable.

### USE OF GREASE

As mentioned above, the use of grease is not recommended. However, if grease lubrication is essential the following points should be noted:

- Limit chain speed to 4 metre/sec.
- Applying normal greases to the outside surfaces of a chain only seals the bearing surfaces and will not work into them. This causes premature failure. Grease has to be heated until fluid and the chain are immersed and allowed to soak until all air bubbles cease to rise. If this system is used the chains need regular cleaning and regreasing at intervals, depending on the drives, power and speed.

### ABNORMAL AMBIENT TEMPERATURES

For elevated temperatures up to 250°C, dry lubricants such as colloidal graphite or MoS<sub>2</sub> in white spirit or poly-alkaline glycol carriers are most suitable.

Conversely, at low temperatures between -5° and -40°C, special low temperature initial greases and subsequent oil lubricants are necessary. Lubricant suppliers will give recommendations.

### LUBRICATING METHODS

There are four basic methods for lubricating chain drives. The recommended methods are shown in the rating charts which are determined by the chain speed and power transmitted.

#### TYPE 1, Manual Lubrication

Oil is applied periodically with a brush or oil can, preferably once every 8 hours of operation. Volume and frequency should be sufficient to just keep the chain wet with oil and allow penetration of clean lubricant into the chain joints.

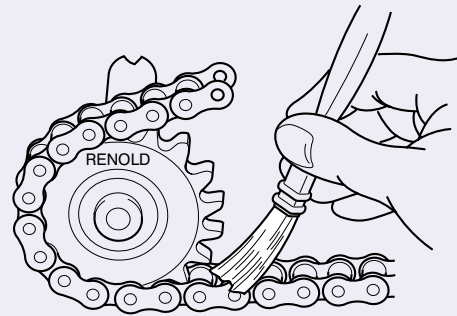

Applying lubricant by aerosol can be satisfactory under some conditions, but it is important that the aerosol lubricant is of an approved type for the application, such as that supplied by Renold. This type of lubricant penetrates into the pin/bush/roller clearances, resisting both the tendency to drip or drain when the chain is stationary and centrifugal "flinging" when the chain is moving.

#### TYPE 2, Drip Lubrication

Oil drips are directed between the link plate edges from a drip lubricator. Volume and frequency should be sufficient to allow penetration of lubricant into the chain joints.

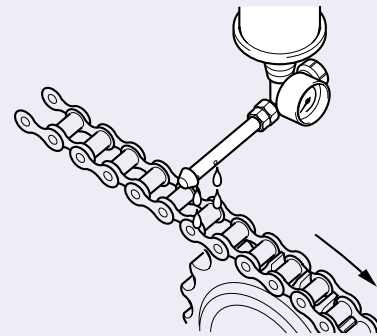

#### TYPE 3, Bath or Disc Lubrication

With oil bath lubrication, the lower strand of chain runs through a sump of oil in the drive housing. The oil level should cover the chain at its lowest point during operation.

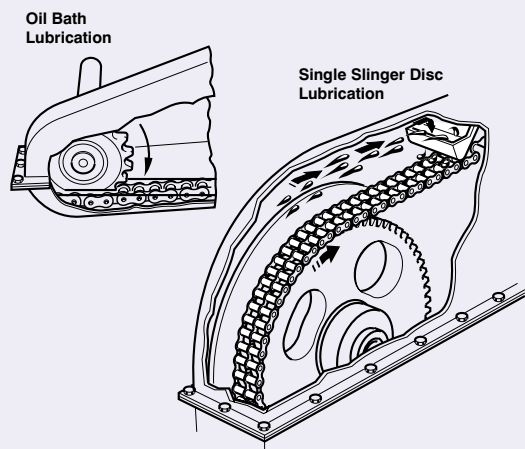

## Chain Installation and Maintenance

With slinger disc lubrication, an oil bath is used but the chain operates above the oil level. A disc picks up oil from the sump and deposits it on the chain by means of deflection plates. When such discs are employed they should be designed to have peripheral speeds between 180 to 2240 metre/min.

### TYPE 4, Stream Lubrication

A continuous supply of oil from a circulating pump or central lubricating system is directed onto the chain. It is important to ensure that the spray holes from which the oil emerges are in line with the chain edges. The spray pipe should be positioned so that the oil is delivered onto the chain just before it engages with the driver sprocket.

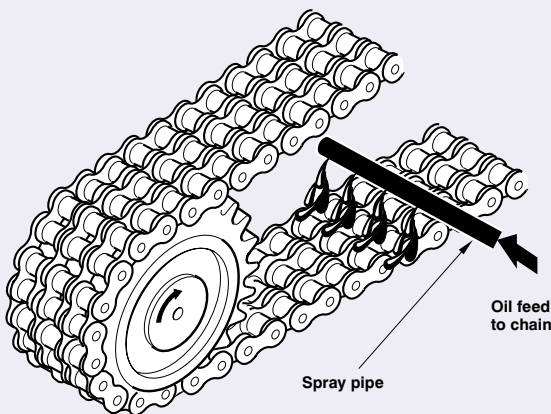

This ensures that the lubricant is centrifuged through the chain and assists in cushioning roller impact on the sprocket teeth. Stream lubrication also provides effective cooling and impact damping at high speeds. It is, therefore, important that the method of lubrication specified is closely followed.

### EFFECT OF TEMPERATURE

During operation an important factor to control in a drive system is the chain and chaincase temperature. Depending on the severity of the drive service, continuity of use, etc., special attention to the lubrication method may be required.

Chain temperatures above 100°C should be avoided if possible due to lubricant limitations, although chain can generally give acceptable performance up to around 250°C in some circumstances. A way of improving the effectiveness of the lubrication and its cooling effect is to increase the oil volume (up to 4.5 litres per minute per chain strand) and incorporate a method of external cooling for the oil.

### To Measure Chain Wear

A direct measure of chain wear is the extension in excess of the nominal length of the chain and the chain wear can, therefore, be ascertained by length measurement in line with the instructions given below.

- Lay the chain, which should terminate at both ends with an inner link (part No. 4), on a flat surface and, after anchoring it at one end, attach to the other end a turnbuckle and a spring balance suitably anchored.
- Apply a tension load by means of the turnbuckle amounting to:

For simple chain:  $P^2 \times 0,77$  Newtons  
 For duplex chain:  $P^2 \times 1,56$  Newtons  
 For triplex chain:  $P^2 \times 2,33$  Newtons  
 Where P is the pitch in mm.

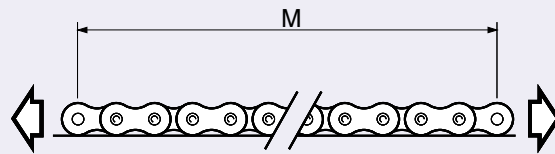

In the case of extended pitch chains (e.g. chains having the same breaking load and twice the pitch) apply a measuring load as for the equivalent short pitch chains.

As an alternative to the use of a turnbuckle and spring balance, the chain may be hung vertically and the equivalent weight attached to the lower end.

- Measure length 'M' (see diagram) in millimetres from which the percentage extension can be obtained from the following formula:

$$\text{Percentage extension} = \frac{M - (X \times P)}{X \times P} \times 100$$

Where X = number of pitches measured  
 P = pitch in mm

- As a general rule, the useful life of the chain is terminated and the chain should be replaced when the percentage extension reaches 2 per cent (1 per cent in the case of extended pitch chains). For drives with no provision for adjustment, the rejection limit is lower, dependent upon the speed and layout. A usual figure is between 0.7 and 1.0 per cent extension.

### RENOLD CHAIN WEAR GUIDE

A simple to use chain wear guide is available from Renold Chain for most popular sizes of chain pitch. Please contact your sales office for details.

### Riveting Chain Endless

#### TRANSMISSION CHAINS UP TO 63.5mm (2.5") PITCH

- Insert the bearing pins of the outer link (No. 107) through the inner links of the chain to be joined. If multiplex chain, assemble intermediate plates at the same time.
- Provide support for the outer link (No. 107) while assembling the separate outer plate. This has a force fit and is driven onto the bearing pins using a hollow punch alternatively on each pin. Drive up to the shoulder on the shouldered bearing pins. Where there is no shoulder the plate is driven to the point of similar clearance between outer and inner links as with the adjacent chain.

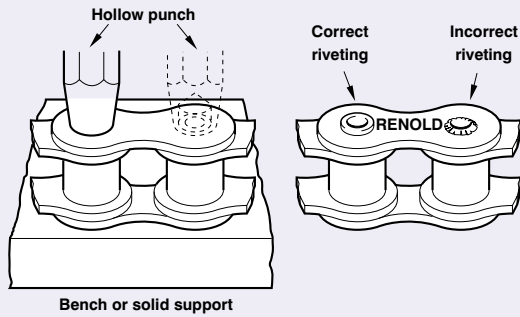

- Still supporting the outer link (No. 107), rivet the bearing pin ends, taking care to finish with a neat uniform spread having a similar appearance to the machine riveted pins in the adjacent chain. The force required to spread the pin end will vary with the pitch of the chain; excessive riveting force should always be avoided. Except where final chain joining in-situ is necessary, the work should be carried out on a bench.
- Check that the newly fitted link articulates freely in the adjacent inner links.

### Chain Length Alterations

All drives should be designed wherever possible, with sufficient overall adjustment to ensure the use of an even number of pitches throughout the useful life of the chain. Cranked links should never be used on impulsive, highly loaded or high speed chain drives.

In less arduous conditions where there is no other solution and the use of a cranked link is unavoidable, the diagrams show how length alteration can be accomplished.

A chain having an even number of links requires the incorporation of a cranked link to effect an alteration of one pitch.

Chain having an odd number of links incorporates a cranked link which must be removed to effect an alteration of one pitch.

By removing the parts shown in dark shading and substituting those in light shading a chain can be shortened or lengthened by one pitch.

No joint which relies on a press fit for assembly should be reused after removal. A new joint should always be employed.

#### Using Cranked Link Double No. 30 (or No. 12 where 30's are not available).

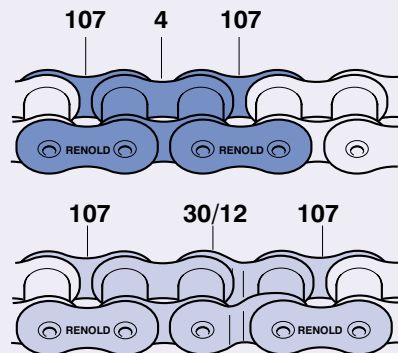
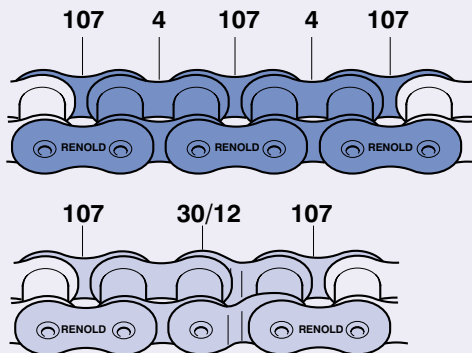

#### To shorten an even link chain by one pitch

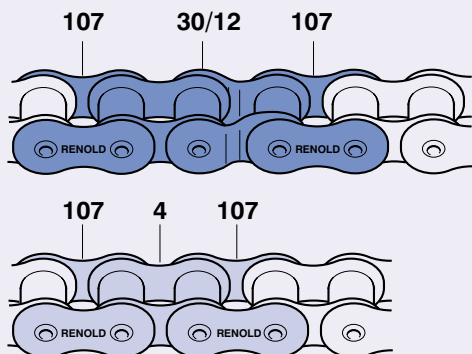

#### To lengthen an even link chain by one pitch

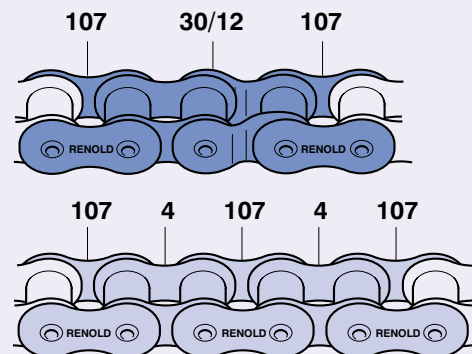

#### To shorten an odd link chain by one pitch

#### To lengthen an odd link chain by one pitch

## Chain Installation and Maintenance

### Pairing and Matching Chains

Any application in which two or more strands of transmission chain are required to operate side by side in a common drive or conveying arrangement, may involve the need for either pairing or matching, and such applications generally fall into one of the following categories:

#### Length Matching for Conveying and Similar Applications

Wherever length matching of transmission chain is necessary it is dealt with as follows:

- The chains are accurately measured in handling lengths between 3m to 8m as appropriate and then selected to provide a two (or more) strand drive having overall length uniformity within close limits. However, such length uniformity will not necessarily apply to any intermediate sections along the chains, but the actual length of all intermediate sections, both along and across the drive, will not vary more than our normal manufacturing limits. However, adapted transmission chains are usually manufactured to specific orders which are generally completed in one production run so that it is reasonable to assume that length differences of intermediate sections will be small.
- Chains are supplied in sets which are uniform in overall length within reasonably fine limits and will be within our normal manufacturing limits. It should be noted that chain sets supplied against different orders at different times may not have exactly the same lengths to those supplied originally, but will vary by no more than our normal tolerance of 0.0%, +0.15%.

#### Pitch Matching Transmission Drive Chains

Pitch matched chains are built up from shorter subsections (usually 300 to 600mm lengths) which are first measured and then graded for length. All subsections in each grade are of closely similar length and those forming any one group across the set of chains are selected from the same length grade.

The requisite number of groups are then connected to form a pitch matched set of chains, or alternatively, if this is too long for convenient handling, a set of handling sections for customer to assemble as a final set of pitch matched chain. Suitable tags are fixed to the chains to ensure they are connected together in the correct sequence.

#### Identification of Handling Lengths

	Handling Length 1	Handling Length 2	Handling Length 3
A Strand	A-A1	A1-A2	A2-A3
B Strand	B-B1	B1-B2	B2-B3
C Strand	C-C1	C1-C2	C2-C3

Long chains are made up in sections, each section being numbered on end links. Sections should be so joined up that end links with similar numbers are connected. Where chains are to run in sets of two or more strands, each strand is stamped on end links of each section with a letter, in addition to being numbered. Correct consecutive sections for each strand must be identified from the end links and joined up as indicated.

By these means, the actual length of any intermediate portion of one strand (as measured from any one pitch point to any other) will correspond closely with that of the transversely equivalent portion on the other strands, generally within 0.05mm, depending on the chain pitch size.

### Pitch Matching Adapted Transmission Chains

(when attachments are fitted to chains)

With the sole exception of extended bearing pins, it is not possible to match the pitch of holes in attachments themselves to within very fine limits, due to the additional tolerances to be contended with (bending, holing, etc.).

#### Colour Coding

For customers who wish to match their chains, perhaps in order to fit special attachments in situ, Renold colour code short lengths of chain within specified tolerance bands. These will normally be RED, YELLOW or GREEN paint marks to indicate lower, mid and upper thirds of the tolerance band. For even finer tolerance bands additional colours can be used, but normally a maximum of five colours will be more than adequate.

COLOUR		
RED		0.05%
YELLOW		0.10%
GREEN		0.15%
BLUE		For Finer
WHITE		Tolerances

### Repair and Replacement

#### SPROCKETS

Examination of the tooth faces will give an indication of the amount of wear which has occurred. Under normal circumstances this will be evident as a polished worn strip about the pitch circle diameter on each of the sprocket teeth as shown below.

If the depth of this wear 'X' has reached an amount equal to 10% of the 'Y' dimension, then steps should be taken to replace the sprocket. Running new chain on sprockets having this amount of tooth wear will cause rapid chain wear.

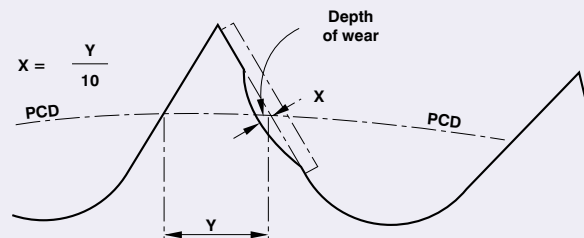

It should be noted that in normal operating conditions, with correct lubrication the amount of wear 'X' will not occur until several chains have been used.

### CHAIN

Chain repair should not as a rule be necessary. A correctly selected and maintained chain should gradually wear out over a period of time, approximately 15000 hours, but it should not fail. A length extension check as detailed on page 80 will give an indication of the service life remaining.

If a transmission chain sustains damage due to an overload, jam-up, or by riding over the sprocket teeth, it should be carefully removed from the drive and given a thorough visual examination. Remove the lubricating grease and oil to make the job easier.

Depending on the damage, it may be practicable to effect temporary repairs using replacement links (shown on page 5). It is not, however, a guarantee that the chain has not been overstressed and so made vulnerable to a future failure. The best policy therefore is to remove the source of trouble and fit a new chain.

If a chain has failed two or more times, it is certain the chain will fail again in time. If no replacement is immediately available repair the chain, but replace it at the nearest opportunity.

The entire chain should be replaced because of the following reasons:

- The cost of down time to the system or machine can often outweigh the cost of replacing the chain.
- A new or even used portion of chain or joints assembled into the failed chain will cause whipping and load pulsation. This can and probably will produce rapid failure of the chain and will accelerate wear in both the chain and its sprockets.

### Assembling Connecting Links

When assembling a connecting link with a slip fit outer plate, it is necessary that this plate is pushed down on the pins to permit insertion of the fastener. Always ensure the No. 27 spring clip (as is illustrated on the No. 26 joint on page 5), has the closed end in the direction of rotation.

On a press fit connecting link it is necessary to drive the outer plate down far enough on the pins to allow insertion of the two split pins, but not so far as to create a tight joint.

By doing the above, three important things are accomplished.

- The desired clearances between the link plates across the chain width are maintained. Any outer link plate driven too far down the pins 'squeezes' the joint, so that no lubrication can get to the bearing surfaces. Such 'squeezing' of a joint prevents a chain articulating freely around the sprockets.
- Correct assembly of a connecting link into a chain will ensure a smooth gearing action with a minimum of whipping.
- With the split pins or spring clip snugly positioned against the side plate and the closed end of a spring clip fitted in the right direction, there will be less of a tendency for them to work loose and fall off.

### Safety Warnings

#### CONNECTING LINKS

No. 11 or No. 26 joints (slip fit) should not be used where high speed or arduous conditions are encountered. In these or equivalent circumstances where safety is essential, a riveting link No. 107 (interference fit) must be used.

#### GOOD DESIGN PRACTICES

For high speed drives or drives operating in arduous conditions, a properly riveted outer link (No. 107) should always be used for optimum security, in preference to any other form of chain joint.

The use of other connectors and cranked links (No. 12 and No. 30) should always be restricted to light duty, non-critical applications, in drives where an odd number of pitches is absolutely unavoidable.

Wherever possible, drives should have sufficient overall adjustment to ensure the use of an even number of pitches throughout the useful life of the chain. A cranked link joint should only be used as a last resort.

### Health and Safety Warning

The following precautions must be taken before disconnecting and removing a chain from a drive prior to replacement, repair or length alteration.

1. Always isolate the power source from the drive or equipment.
2. Always wear safety glasses.
3. Always wear appropriate protective clothing, hats, gloves and safety shoes as warranted by the circumstances.
4. Always ensure tools are in good working condition and used in the proper manner.
5. Always loosen tensioning devices.
6. Always support the chain to avoid sudden unexpected movement of chain or components.
7. Never attempt to disconnect or reconnect a chain unless the chain construction is fully understood.
8. Always ensure that directions for the correct use of any tools are followed.
9. Never reuse individual components.
10. Never reuse a damaged chain or chain part.
11. On light duty drives where a spring clip (No. 27) is used, always ensure that the clip is fitted correctly with the closed end pointing in the direction of travel.

## Chain Installation and Maintenance

### Troubleshooting

#### PROBLEM

#### PROBABLE CAUSE

#### SOLUTION

#### CHAIN CLIMBING OR JUMPING OFF THE SPROCKET TEETH

- CHAIN OR SPROCKETS WORN
- CHAIN EXCESSIVELY SLACK
- INSUFFICIENT CHAIN WRAP
- FOREIGN MATERIAL BUILD UP IN THE SPROCKET TOOTH GAPS

- REPLACE THE CHAIN AND SPROCKETS IF NECESSARY
- ADJUST THE CENTRE DISTANCE OR INTRODUCE A JOCKEY SPROCKET TO TAKE UP THE SLACK. IF ALLOWABLE, SHORTEN THE CHAIN
- FOR LARGE RATIO DRIVES, THE DRIVER SPROCKET MAY NOT HAVE ENOUGH TEETH TO ABSORB THE WORKING TENSION. IF THE DRIVE CANNOT BE ALTERED, INTRODUCE A JOCKEY SPROCKET TO INCREASE THE CHAIN WRAP
- CLEAN THE SPROCKET TEETH OF ALL MATERIAL SO THAT THE CHAIN ENGAGES CORRECTLY

#### CHAIN DRIVE RUNNING HOT

- LUBRICATION METHOD OR TYPE OF LUBRICATION IS UNSUITABLE FOR THE OPERATING SPEED AND POWER BEING TRANSMITTED
- INSUFFICIENT LUBRICATION
- CHAIN CONTINUALLY HITTING AN OBSTRUCTION
- INCORRECT CHAIN SIZE SELECTED FOR THE SPEED AND TRANSMITTED POWER

- CHECK THE CATALOGUE SELECTION TABLES FOR THE CORRECT LUBRICATION METHOD
- INCREASE THE FREQUENCY OF LUBRICATION IN LINE WITH GOOD MAINTENANCE PRACTICE
- REMOVE THE OBSTRUCTION
- CHECK THE CHAIN SELECTION AS A SMALLER PITCH OR MULTISTRAND CHAIN OF EQUIVALENT CAPACITY MAY BE REQUIRED

#### CHAIN ELONGATION (A GRADUAL INCREASE OVER ITS LIFE IS NORMAL)

- LUBRICATION FAILURE
- AN OVERLOAD
- DISPLACEMENT OF THE BEARINGS
- FAILURE OF THE TENSIONING DEVICE

- REPLACE CHAIN AND SPROCKETS
- CHECK LUBRICATION, DRIVE CONFIGURATION AND LOADINGS
- MONITOR DRIVE ELONGATION OVER A PERIOD OF 2-3 MONTHS BY CHECKING THE DEGREE OF SAG
- CONTACT OUR TECHNICAL STAFF FOR ADVICE IF PROBLEM PERSISTS

#### CHAIN STIFFENS, STARTS TO WHIP

- WORN CHAIN OR SPROCKETS
- EXCESSIVELY SLACK CHAIN
- HEAVY & IMPULSIVE LOAD
- CENTRE DISTANCE TOO LONG
- ONE OR MORE STIFF JOINTS

- REPLACE CHAIN AND SPROCKETS
- ADJUST CENTRES IF POSSIBLE OR INTRODUCE A TAKE-UP SYSTEM SUCH AS A JOCKEY SPROCKET. IT IS ALSO POSSIBLE TO SHORTEN THE CHAIN BY ONE OR MORE PITCHES
- REDUCE THE LOADING
- ADD A JOCKEY SPROCKET ON LONG CENTRE DISTANCES
- REMOVE OR REPAIR STIFF JOINTS

PROBLEM	PROBABLE CAUSE	SOLUTION
<b>EXCESSIVE NOISE</b>	■ MISALIGNMENT OF SPROCKETS	■ MISALIGNMENT INTRODUCES ABNORMAL LOADING AND WEAR. RECHECK ALIGNMENT TO MAINTAIN NORMAL DRIVE CONDITIONS
	■ INADEQUATE LUBRICATION	■ IMPROVE THE LUBRICATION METHOD TO ENSURE THE PROPER AMOUNT OF LUBRICATION IS AVAILABLE IN THE BEARING AREAS
	■ WORN OR INCORRECTLY FITTED BEARINGS	■ REPLACE OR CORRECT THE BEARINGS AS THESE WILL MALIGN THE ENTIRE DRIVE
	■ CHAIN EXCESSIVELY SLACK OR TIGHT	■ ADJUST THE CENTRE DISTANCE IF POSSIBLE OR INTRODUCE A JOCKEY SPROCKET
	■ WORN CHAIN OR SPROCKETS	■ REPLACE THE CHAIN AND WHERE NECESSARY THE SPROCKETS. CONSIDER HARDENED TEETH
	■ TIGHT JOINTS	■ REPLACE OR REPAIR JOINTS
	■ HEAVY IMPULSIVE LOADS	■ REDUCE THE LOAD OR INTRODUCE A JOCKEY SPROCKET
	■ CHAIN PITCH SIZE TOO LARGE	■ CHECK THE CHAIN SELECTION OR CONTACT OUR TECHNICAL STAFF
	■ OBSTRUCTION IN THE CHAINS PATH	■ REMOVE THE OBSTRUCTION
<b>HEAVY WEAR ON SPROCKET TEETH WORKING FACES. (A BRIGHT POLISHED APPEARANCE IS NORMAL)</b>	■ POOR LUBRICATION	■ IMPROVE THE METHOD OF LUBRICATION, ( SEE LUBRICATION SECTION)
	■ PRESENCE OF ABRASIVE	■ CHECK FOR PRESENCE OF FOREIGN MATERIALS AND ELIMINATE THE SOURCE. REPLACE SPROCKETS AND CHAIN IF NECESSARY
<b>PIN FAILS</b>	■ SYSTEM LOADING IS GREATER THAN THE CAPACITY OF THE CHAIN	■ CHECK THE KILOWATT RATING TABLE TO DETERMINE IF THE CHAIN CAPACITY HAS BEEN EXCEEDED. LARGER PITCH CHAIN OR A MULTISTRAND CHAIN MAY BE REQUIRED IF THE LOAD CONDITIONS CANNOT BE CORRECTED
<b>ROLLER OR BUSH FAILS</b>	■ CHAIN CAPACITY HAS BEEN EXCEEDED AT HIGH SPEED CAUSING IMPACT ON THE SPROCKET TEETH	■ CHECK THE DRIVE SELECTION. A SMALLER PITCH CHAIN, A MULTISTRAND CHAIN OR SPROCKETS WITH MORE TEETH MAY BE REQUIRED
	■ TOOTH MARKS ON THE OUTSIDE OF THE ROLLER DIAMETER CAN INITIATE FAILURE	■ IF THE ROLLERS ARE MARKED BY THE SPROCKET TEETH, ADJUST THE CENTRE DISTANCE

## Chain Installation and Maintenance

### Troubleshooting

#### PROBLEM

#### PROBABLE CAUSE

#### SOLUTION

##### RUST PRESENT ON CHAIN

- INADEQUATE LUBRICATION. THIS WILL ALSO AFFECT THE JOINTS WHICH WILL BE DISCOLOURED, (LIGHT TO DARK BROWN) AND COULD BE ROUGH, GROOVED OR GALLED

- REMOVE SEVERAL JOINTS AND CHECK THAT THE COMPONENTS ARE NOT SEVERELY DAMAGED. REPLACE CHAIN AND SPROCKETS AS NECESSARY. IMPROVE LUBRICATION METHOD.

##### SIDE PLATE FAILS

- FATIGUE FAILURE IS CAUSED BY REPETITIVELY LOADING THE CHAIN ABOVE ITS LIMIT
- IMPULSIVE DRIVE CONDITIONS CAN ALSO CAUSE FATIGUE FAILURE

- CHECK THE DRIVE SELECTION, A LARGER PITCH CHAIN OR A MULTISTRAND CHAIN MAY BE REQUIRED
- IF NOT THE ABOVE, CHECK FOR EXCESSIVE SLACK. THIS MAY INDICATE WORN CHAIN AND SPROCKETS. REPLACE WHERE REQUIRED

##### SIDE PLATES ARE WORN

- WEAR ON THE INSIDE OF THE PLATE IS CAUSED BY SPROCKET MISALIGNMENT
- WEAR ON THE TOP OF THE SIDE PLATE IS CAUSED BY THE CHAIN RUBBING AGAINST THE CHAINCASE OR SOME OBSTRUCTION

- CHECK AND ADJUST SPROCKET AND SHAFT ALIGNMENT
- REMOVE SOURCE OF RUBBING BY REMOVING THE OBSTRUCTION OR ADDING A JOCKEY SPROCKET TO CONTROL THE SLACK IN THE CHAIN

##### WEAR ON THE SIDES OF THE SPROCKET TEETH

- DRIVE MISALIGNMENT

- CHECK AND CORRECT SPROCKET AND SHAFT ALIGNMENT